

8510 High-Voltage Compressor

(For Use with On-Board High-Vacuum Pumps)

Installation, Operation and Service Instructions

8040265
Rev. P (3/97)

The information in this document is believed to be accurate and reliable. However, Helix Technology Corporation, cannot accept any financial or other responsibilities that may result from the use of this information. No warranties are granted or extended by this document.

Helix Technology Corporation reserves the right to change any or all information contained herein without prior written notice. Revisions may be issued at the time of such changes and/or deletions.

Any duplication of this manual or any of its parts without expressed written permission from Helix Technology Corporation is strictly prohibited.

Any correspondence regarding this document should be forwarded to:

Helix Technology Corporation
Mansfield Corporate Center
Nine Hampshire Street
Mansfield, Massachusetts 02048-9171 U.S.A.

Telephone: (508) 337-5000
FAX: (508) 337-5464

The following Helix Technology Corporation trademarks and service marks may appear in this document:

CTI-Cryogenics®	GUTS®
Cryo-Torr®	Cryodyne®
Cryogem®	Cryogenerator®
On-Board®	Helix®
RetroFast®	
Value Line™	RetroEase®
FastRegen™	TurboPlus®
TurboLink™	
ThinLine™	

All other trademarks or registered trademarks are the property of their respective holders.

Table of Contents

Section 1 - Introduction

General	1-1
Installation, Operation and Service Instructions	1-1

Section 2 - Inspection

Packaging of the System	2-1
The Compressor	2-1

Section 3 - Installation

Compressor Installation	3-2
Preparing the Compressor	3-2
Assembling the Compressor Input-Power Cable	3-3
Electrical Preparation of Compressor Control Module	3-4
Cooling Water: Preparation	3-4
Cooling Water: General Considerations	3-5
Cooling Water: Flow and Pressure Requirements	3-7
Cooling Water: Temperature Rise	3-8
Oil Circuit Stabilization	3-9
Connecting the Compressor to the Cryopump	3-9
Electrical Connection of Compressor	3-10
8510 High-Voltage Compressor Electrical Phase Check and Automatic ON/OFF Control	3-11
System Phase Input Checkout Procedure	3-11
Automatic ON/OFF Control of the Compressor Using the On-Board Setpoint Relays	3-11
Multipump Installation	3-12

Section 4 - Maintenance Procedures

Scheduled Maintenance	4-1
Removing the Compressor Adsorber	4-2
Installing the Compressor Adsorber	4-3
Unscheduled Maintenance	4-4
Suggested Unscheduled Maintenance Equipment	4-4
Adding Helium Gas	4-4
Helium Circuit Decontamination	4-6
Cryopump Decontamination Procedures	4-6
Compressor Decontamination Procedures	4-8
Priming the Compressor Oil System	4-9

Table of Contents (continued)

Appendix A - Customer Support Centers

Appendix B - Troubleshooting Procedures

Appendix C - Electrical Schematic for 8510 High-Voltage Compressor

Appendix D - Components in the Electrical Control Module of 8510 High-Voltage Compressor

Appendix E - Compressor Flow Diagram

Appendix F - Multiple Cryopump Installation with Single 8510 High-Voltage Compressor

Figures

Figure 1-1: 8510 High-Voltage Compressor: Front and Side Views	1-2
Figure 1-2: 8510 High-Voltage Compressor	1-5
Figure 3-1: Block Diagram for 8510 High-Voltage Compressor Installation . .	3-1
Figure 3-2: Removing Compressor Pump Shipping Supports	3-2
Figure 3-3: Preparing the 8510 High-Voltage Compressor Control Module . .	3-6
Figure 3-4: Model 8510 High-Voltage Compressor Cooling Water Flow and Pressure Requirements	3-7
Figure 3-5: 8510 High-Voltage Compressor Water Discharge Temperature Increase (°F)	3-9
Figure 3-6: 8510 High-Voltage Compressor Installation	3-13
Figure 4-1: Connecting/Disconnecting the Adsorber Self-sealing Couplings . .	4-2
Figure C-1: 8510 (High Voltage) Compressor Schematic	C-2
Figure D-1: Components in the Electrical Control Module of 8510 High-Voltage Compressor	D-3

Table of Contents (continued)

Figure E-1: 8510 High-Voltage Compressor Flow Diagram E-1

Figure F-1: Typical Multiple Cryopump Installation with Single 8510
High-Voltage Compressor F-1

Tables

Table 1-1: Compressor Dimensions P/N 8031400G002 1-2

Table 1-2: Power Requirements (Steady-State Conditions) 1-2

Table 1-3: General Specification 1-3

Table 2-1: 8510 Carton Contents 2-1

Table 3-1: 8510 High-Voltage Compressor Power Specifications 3-6

Table 3-2: Setpoint Relay Connections 3-11

Table A-1: Customer Support Centers A-2

Table B-1: Compressor Troubleshooting Procedures B-2

Table D-1: Legend for Figure D-1 D-1

Section 1 - Introduction

General

The manual provides instructions for installing, operating and servicing the 8510 High-Voltage Compressor, P/N 8031400G002 (380-460 volts). If you are installing or operating an On-Board High-Vacuum System you should also have available the On-Board High-Vacuum Pump Manual that applies to your particular system:

- 8040215 On-Board 8 and 8F High-Vacuum Pumps
- 8040233 On-Board 10 and 400 High-Vacuum Pumps

The manuals for a system cover two basic components: the high-vacuum pump and the compressor. Each manual outlines the details necessary for installation, operation and servicing of that component. A manual is shipped with each system component (high-vacuum pump and compressor). When you purchase a system, you will receive the two manuals necessary for system installation, plus a loose-leaf binder with index tab separators, allowing you to compile a complete indexed system notebook.

Installation, Operation and Service Instructions

Installation, Operation and Service Instructions for your 8510 High-Voltage Compressor provide easily accessible information. All personnel with installation, operation, and servicing responsibilities should become familiar with the contents of these instructions to ensure high quality, safe, reliable performance. Unit must be wired by an authorized electrician in accordance with the national electrical code, ANSI/NFPA 70-1987, as well as the local codes.

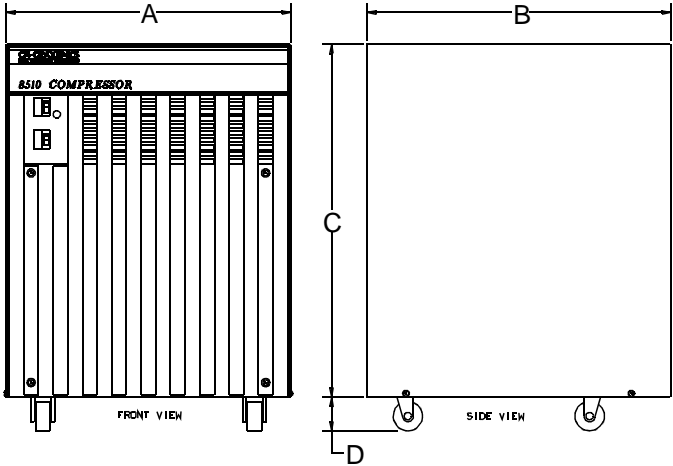

Figure 1-1: 8510 High-Voltage Compressor: Front and Side Views

Table 1-1: Compressor Dimensions P/N 8031400G002

Location	Compressor Dimension Inches (mm)
A	19.52 max. (496 mm)
B	21.50 max. (546 mm)
C	24.24 max. (616 mm)
D	2.30 (58 mm)

Table 1-2: Power Requirements (Steady-State Conditions)

Compressor	Volts	Hz	Phase	Full Load Current (Amps)	Operating Voltage Range (Volts)	Maximum Phase Run Current (Amps)
8510, Part No. 8031400G002	460	60	3	8	395-506	11
	380	50	3	8	342-457	11

Table 1-3: General Specification

Specification	Description
Weight	340 lbs (154 kg) approximate
Weight (shipping)	445 lbs (202 kg) approximate
Power consumption	5.4 kw, nominal operating power, 6.2 kw maximum 0.8 power factor, 7.8 kva maximum
Compressor input-power cable (customer-supplied)	Recommended type SO-4 conductor, 600V, neoprene jacket and 10-gauge or 4mm ² minimum wire. Install per Figure B-1, Electrical Schematic Diagram, ensuring compliance with all national, state and local standards.
Helium pressure	Static: 195-205 psig (1345-1415 kPa) at 70 to 80°F (21 to 27°C) Return: Normal operation: 75-85 psig (517-590 kPa) at operating temperature.
Ambient operating temperature range	50 to 100°F (10 to 38°C)
Interface	Cold head power receptacles (3): Mates with plugs on cold head power cables. Compressor input-power termination: Connects with #10 (5mm) ring terminals. Gas-supply connector: 1/2-inch self-sealing coupling Gas-return connector: 1/2-inch self-sealing coupling Remote control receptacle 24VAC, 150ma: Mates with J5 connector P/N MS3106A-20, supplied by CTI-CRYOGENICS.
Adsorber service schedule	Replace every three years.
Cooling water requirements	70°F water supply, 2.5 gpm, 14 psid (pressure drop: water inlet to water outlet). The pressure value does not consider discharge back-pressure conditions. Maximum/minimum water requirements Maximum outlet temperature 100°F (38°C) Minimum inlet temperature 40°F (4°C) Maximum inlet pressure 100 psig

This compressor has been designed to operate with water having a pH value of 6.0 to 8.0 and a calcium carbonate concentration of less than 75 parts per million (typical municipal drinking water quality). For applications of lower pH or greater hardness, water conditioning may be necessary.

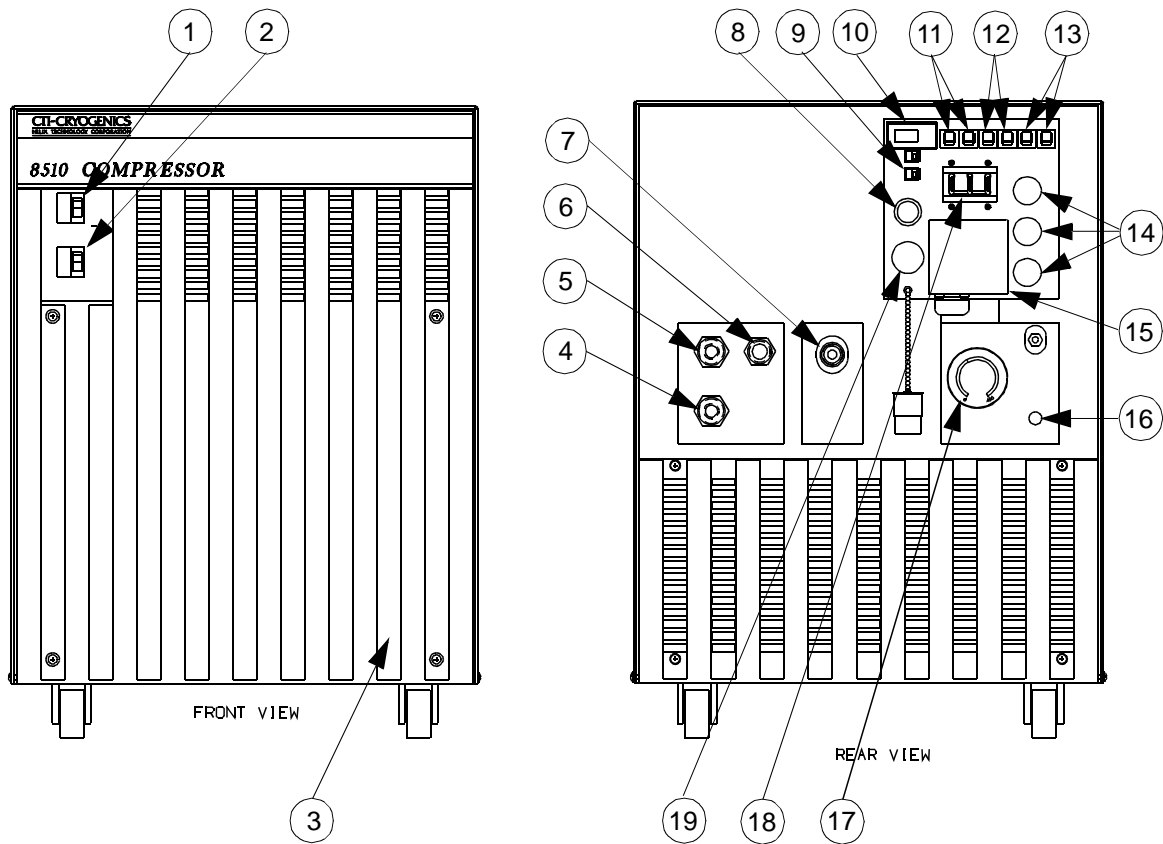

LEGEND

- | | |
|---|--|
| 1. Compressor Power ON/OFF Switch (with ON lamp) | 11. Elapsed time meter (ETM). |
| 2. On-Board System Power Switch (with ON Lamp) | 12. Cold head power circuit breakers (CB2 and CB3). |
| 3. Oil sight glass | 13. Cold head power cable receptacles (J2, J3, and J4). |
| 4. Cooling water output. | 14. Input power cable receptacle (J1). |
| 5. Cooling water input. | 15. Helium return pressure gauge. |
| 6. Helium gas-return connector self-sealing coupling. | 16. Helium gas charge fitting and valve. |
| 7. Helium gas-supply connector self-sealing coupling. | 17. Safety interlock. |
| 8. Compressor overload reset. | 18. System power ON/OFF switch circuit breaker (CB1). |
| 9. Voltage selector switches (S3). | 19. System remote control receptacle (J5) (Jumper plug installed). |
| 10. Voltage selector switches (S2). | |

Figure 1-2: 8510 High-Voltage Compressor

Section 2 - Inspection

Packaging of the System

The On-Board High-Vacuum Pump System is packaged in three separate cartons. Listed below are the contents of each carton, as they relate to these two system applications. Note that an Installation, Operation, and Service Manual is included in cartons for the high-vacuum pump and compressor. Each manual covers the component packaged in that carton.

When installing an On-Board High-Vacuum Pump System, CTI-CRYOGENICS recommends that as you unpack a component: perform an inspection and the necessary tasks for system installation for the component according to the manual included with the component. Final system installation and operation will be performed following procedures in the On-Board 8/8F or 10 and 400 Cryopump Manual (No. 8040215 or 8040233 respectively).

Table 2-1: 8510 Carton Contents

Carton Label	On-Board 8/8F, 10 And 400 High-vacuum Pump System Carton Contents	Manual Included
On-Board	On-Board 8/8F Cryopumps	8040215
On-Board	On-Board 10 and 400 Cryopumps	8040233
Compressor	8510 High-Voltage Compressor	8040265
Accessories	Installation and Scheduled Maintenance Tool Kit and Accessories, P/N 8032040G014	—

The Compressor

On receipt, remove the 8510 High-Voltage Compressor from its shipping carton and inspect the compressor for evidence of damage as described in this Section.

1. Unpackage and remove the compressor from its shipping carton.
2. Check the carton contents. It should contain:
 - a. 8510 High-Voltage Compressor.

- b. Two barbed fittings for compressor cooling water connections.
- c. Compressor remote start connector.
- d. Input power connector.
- e. Oil prime manifold, P/N 8018129.
- f. 8510 High-Voltage Compressor Manual P/N 8040265.

Section 3 - Installation

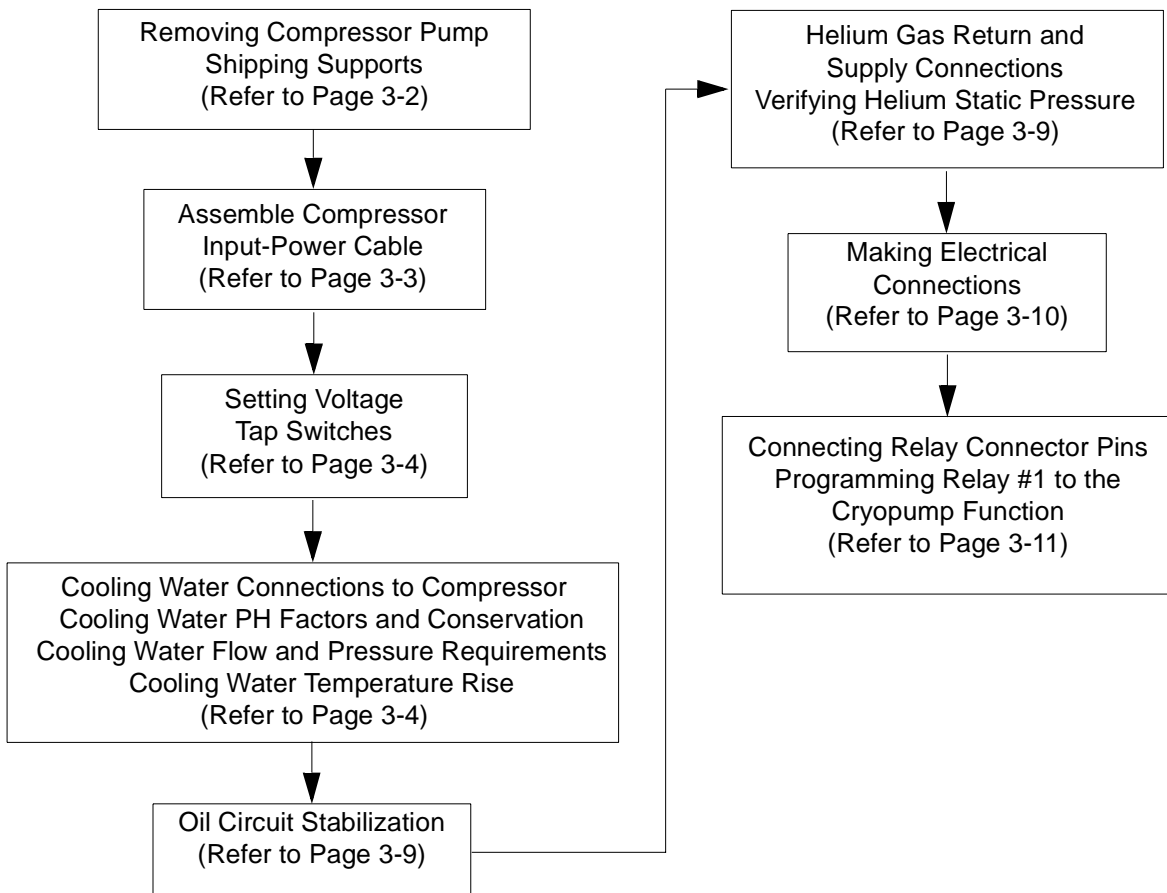

Figure 3-1: Block Diagram for 8510 High-Voltage Compressor Installation

Compressor Installation

Installation of your compressor requires no special tools other than those supplied in the Installation and Scheduled Maintenance Tool Kit.

Preparing the Compressor

1. After removing the compressor front panel, refer to Figure 3-2 and remove the front two compressor pump shipping supports.
 - a. Remove the front two nuts and red flat washers that secure the compressor pump tightly in position.

NOTE: Retain the two red flat washers for use during shipment.

- b. Remove the two rubber grommets that are in the package attached to the compressor: install them, flat side up, onto the front two mounting posts.
- c. Reinstall the two nuts and screw them down flush with the tops of the mounting posts.
- d. Replace the compressor front panel.

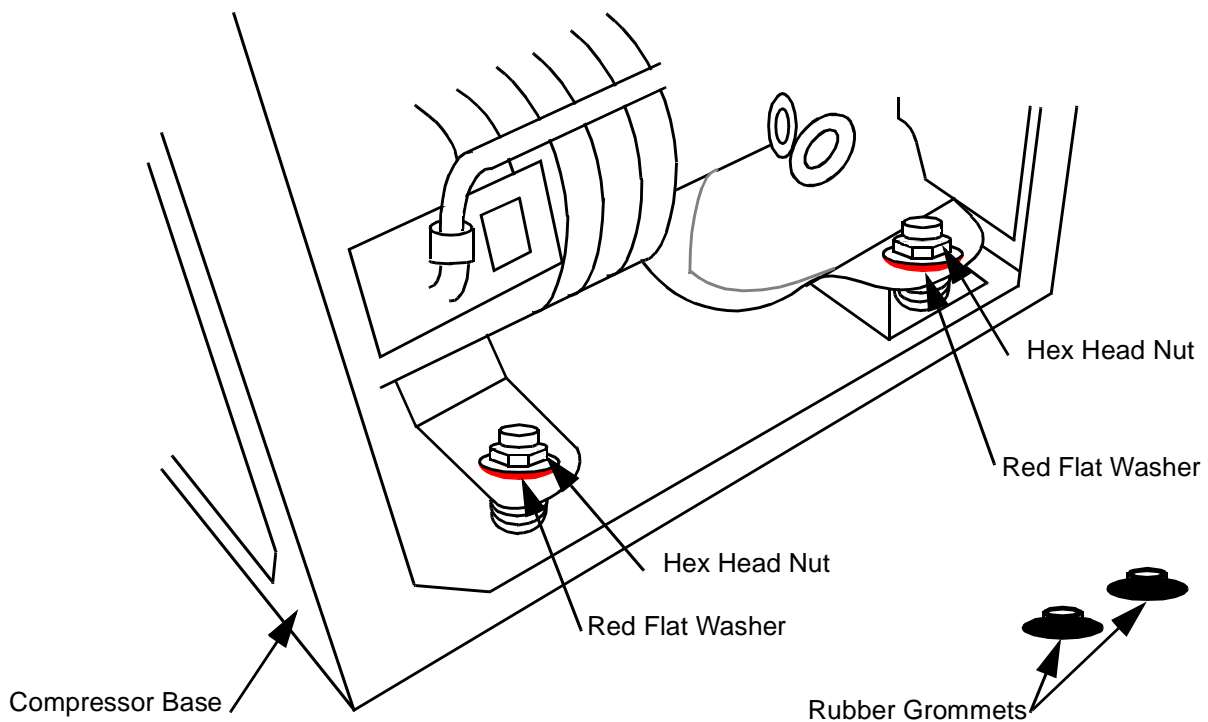

Figure 3-2: Removing Compressor Pump Shipping Supports

Assembling the Compressor Input-Power Cable

To supply input power to the compressor requires the fabrication of a 600-volt power cable that has an SO-4 conductor, 600-volt rating neoprene jacket and 10-gauge or 4 mm² wire. Proceed as follows:

WARNING

Do not connect the compressor to the power source at this time. All of the preparation must be completed and all panels reinstalled before electrically connecting the compressor.



Unit must be wired by an authorized electrician in accordance with the national Electrical Code, ANSI/NFPA 70-1996, as well as the local codes. This shall include installation of a readily accessible disconnect device into the fixed wiring supplying power.

An insulated safety grounding conductor that is identical in size, insulation material and thickness to the circuit supply conductors, except that it is green with or without one or more yellow stripes is to be installed as part of the branch circuit which supplies the unit or system. The grounding conductor described is to be connected to the equipment grounding conductor of the supply circuit.

1. Prepare the input power cable by terminating each of the four conductors with a #10 ring terminal. Follow the terminal manufacturer's instructions to insure proper crimping.
2. Disassemble the electrical terminal enclosure cover, mounted on the control module, as shown in Figure 3-3. Remove the two screws securing the cover and lift it off.
3. If necessary, back off strain relief screws.
4. Thread input power cable end up through the strain relief into the enclosure.
5. Attach the three conductors onto the appropriate terminals of the terminal block; attach the ground conductor to the ground stud of the enclosure. See Figure 3-3. Check that there are no bare conductors exposed.
6. Tighten all terminals to 18-22 in.-lbs. torque.
7. Tighten down screws on strain relief.

CAUTION

Ensure that strain relief is tightened down on the outer insulation of the input power cable and that the cable does not slide.

8. Remount the terminal enclosure cover and secure with two screws.
9. Refer to **Electrical Connection of Compressor** for correct phasing checkout procedure.

**WARNING**

Ensure that the ground wire is returned to the equipment grounding conductor of the circuit supplying the receptacle.

Electrical Preparation of Compressor Control Module

1. Refer to Table 1-2, for electrical power requirements. Then, using a voltmeter, measure the phase-to-phase voltage from the power source.
2. Prepare the compressor voltage selector switches S2 and S3 as required in accordance with Figure 3-3.

Cooling Water: Preparation

If flexible water hose connections are used, install the barbed fittings supplied with the compressor on the input and output connections:

1. Apply a light coating of standard plumbing thread sealant on the barbed fitting threads.
2. Tighten fittings on 1/2-inch FPT input and output connections. **DO NOT OVERTIGHTEN.**
3. Connect flexible hoses to the fittings and secure with hose clamps.

If hard piping is desired, install the water lines directly onto the compressor 1/2-inch FPT input and output connections. **DO NOT OVERTIGHTEN.**

CAUTION

Check water connections for leaks.

Cooling Water: General Considerations

NOTE: Adjust your water flow to maintain an optimum discharge water temperature of 80° with a minimum input pressure of 7 psi. For detailed water requirements, see below.

1. Cooling water must meet flow and pressure requirements as indicated in the following subsections.
2. Cooling water having a pH value of 6.0 to 8.0 and a calcium-carbonate concentration of less than 75 ppm, the quality of typical municipal drinking water, is acceptable. If the cooling water has a pH value lower than 6.0 or a calcium-carbonate concentration higher than 75 ppm, water conditioning may be required.
3. To conserve water, the cooling water should be shut off when the compressor is not running.

CAUTION

If cooling water below 45°F (7°C) is allowed to run through the compressor while the compressor is not operating, the compressor oil will change viscosity and thicken, causing the compressor to overheat and shut off at startup. In this event, repeatedly restart the compressor and allow it to run until it has shut off several times. The oil temperature will rise and thereby allow continuous compressor operation.

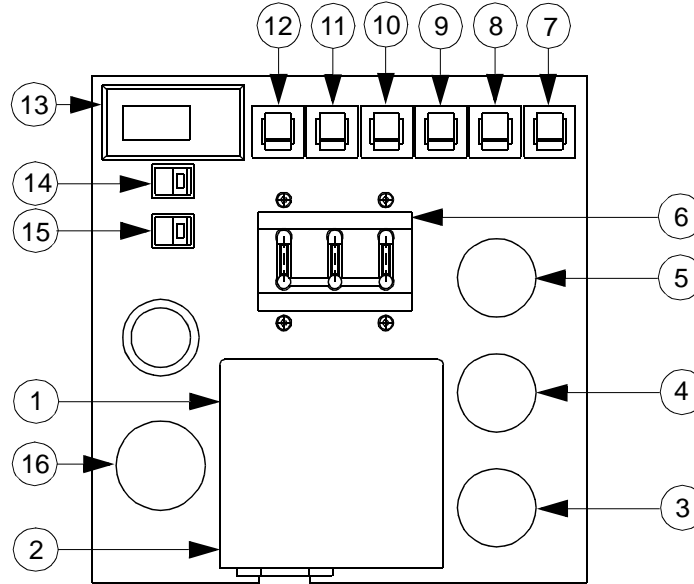

- | | |
|---|--|
| <ul style="list-style-type: none"> 1. Terminal Block 1 2. Terminal Block Cover Screws 3. Cold Head Power Connector (J12) 4. Cold Head Power Connector (J11) 5. Cold Head Power Connector (J10) 6. System Power Switch (CB1) 7. Cold Head Circuit Breaker (CB3) 8. Cold Head Circuit Breaker (CB2) | <ul style="list-style-type: none"> 9. On-Board Circuit Breaker (CB7) 10. On-Board Circuit Breaker (CB7) 11. Heater Circuit Breaker (CB5) 12. Heater Circuit Breaker (CB4) 13. Elapsed time meter 14. Voltage selector switch (S2) 15. Voltage selector switch (S3) 16. System Control Interface Connector (J5) |
|---|--|

Figure 3-3: Preparing the 8510 High-Voltage Compressor Control Module

Table 3-1: 8510 High-Voltage Compressor Power Specifications

Compressor Configuration	Frequency (Hz)	Voltage	Voltage Selector Switch Setting	
			S2	S3
P/N 8031400G002 380/460VAC, 50/60 Hz	50	342-405	2	3
		406-457	2*	4
	60	395-450	2	3
		451-506	2*	4

*Factory setting

- 4. Drain and purge water from the compressor before shipping it back to the factory or subjecting it to freezing conditions. Purge water from the compressor by blowing compressed air, regulated to 30 to 40 psig (200 to 275 kPa) into the compressor output connection and allowing water to exit from the water input connection.

Cooling Water: Flow and Pressure Requirements

CAUTION

If your water supply pressure falls below 7 psig due to back pressure, the compressor will overheat and shut down.

Use the two graphs in Figure 3-4, to determine the minimum acceptable cooling water supply pressure at different flow rates and temperatures. Find the minimum pressure:

NOTE: Without consideration of back pressure.

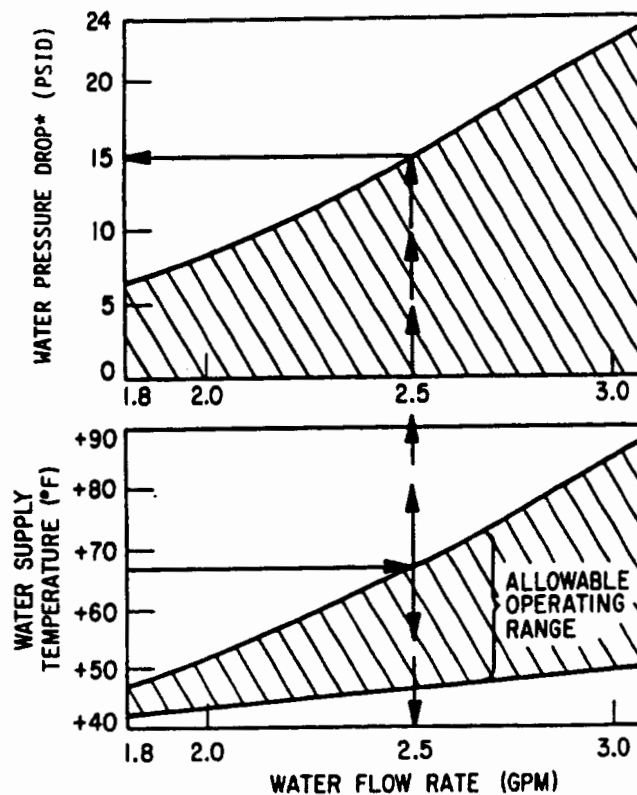

Figure 3-4: Model 8510 High-Voltage Compressor Cooling Water Flow and Pressure Requirements

1. Determine the temperature variation of the cooling water. Allow a $\pm 10^{\circ}\text{F}$ to the present water temperature if a variation cannot be ascertained. Plot the high and low temperatures on the vertical axis of the lower graph.

The example describes cooling water that varies between 45°F and 67°F .

2. Determine the optimum water flow rate by drawing a horizontal line from the upper temperature variation figure on the lower graph to the upper curve of the allowable operating range indicated by cross-hatching. Draw a line from this intersecting point straight down to the horizontal axis to find the optimal flow rate.

The example shows a solid arrow extending from 67°F and intersecting the allowable operating range. Dashed arrows pointing downward indicate a water flow rate of 2.5 gallons per minute.

3. Determine the cooling water supply pressure drop by drawing a line straight up from the flow rate in the lower graph to the upper graph. At the point at which this line intersects the upper graph, draw a line leftward to the vertical axis and find the water supply pressure drop.

The example shows dashed arrows extending from the lower to the upper graph. On the upper graph the dashed arrows intersect the graph curve at approximately 15 psig.

4. Determine the total cooling water supply pressure drop by adding the pressure drop determined from the graph to the water back pressure at the installation site.

Cooling Water: Temperature Rise

CAUTION

The temperature of the cooling water as it leaves the compressor should not exceed 100°F.

Use the graph in Figure 3-5 to determine the rise in cooling water temperature as it passes through the compressor. The recommended discharge temperature for the compressor is 80° F. This information is used by plant engineering personnel to determine cooling water requirements.

Find the temperature rise:

1. Draw a vertical line upward from the horizontal axis of the graph at the water flow rate determined from the previous section, until it hits the graph curve.

The example shows dashed arrows pointing upward to the graph curve from 2.5 gpm on the water flow rate axis.

- At the point which the dashed arrows intersect the graph curve, draw a straight line to the left to obtain the increase in output water temperature.

The example shows a temperature increase of 14°F.

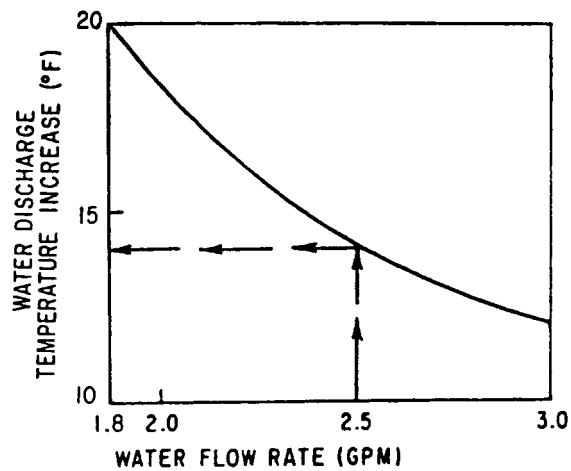

NOTE: Used for clarification of example presented in text.

Figure 3-5: 8510 High-Voltage Compressor Water Discharge Temperature Increase (°F)

Oil Circuit Stabilization

- Check to insure that the cover and all panels are properly installed on the compressor.
- With the system power ON/OFF switch in the OFF position, connect the input-power cable to the power source. If necessary, refer to Table 1-2, for electrical requirements.
- Place the system power switch to the ON position and allow the compressor to run 15 minutes to stabilize the oil circuit. If the compressor shuts down, oil system priming may be necessary. Refer to, **Priming the Compressor Oil System**, for priming procedures.

Connecting the Compressor to the Cryopump

NOTE: If your application requires the use of multiple compressors on a single gas manifold, you must install an external check valve on each compressor. Order CTI-CRYOGENICS Kit P/N 8080275K004 and contact the Product Service Department for installation guidance on manifolding compressors.

Make the connections between the cryopump and compressor. See Figure 3-6.

1. Remove dust plugs and caps from the supply fittings and return lines, compressor, and cryopump cold head. Check all fittings.
2. Connect the helium-gas return line from the gas-return connector on the rear of the compressor to the gas-return connector on the cryopump cold head.
3. Connect the helium-gas supply line from the gas-supply connector on the rear of the compressor to the gas-supply connector on the cryopump cold head.
4. Attach the supply and return line identification decals (CTI-CRYOGENICS supplied) to their respective connecting piping ends.

Verify proper helium supply static pressure by confirming that the helium pressure gauge reads 195-205 psig (1345-1415 kPa), in an ambient temperature range of 50 to 100° F (10 to 38° C).

If the indicated pressure is higher than 205 psig (1415 kPa), reduce the pressure as follows:

1. Remove the flare cap from the gas charge fitting located on the rear of the compressor.
2. Open the gas charge valve very slowly. Allow a slight amount of helium gas to escape until the helium pressure gauge reads 200 psig (1380 kPa).
3. Close the gas charge valve and reinstall the flare cap.

If the indicated pressure is lower than 195 psig (1345 kPa), add helium gas as described in **Adding Helium Gas**.

Electrical Connection of Compressor



WARNING

The system power switch on the rear of the compressor must be in the OFF position before making any and all electrical connections.

1. Connect the power cable to the rear panel of the compressor and the other end to the electrical power connector on the cryopump.

2. Connect the compressor input power cable to the AC power source.
3. Turn the system power switch (CB1) on the rear of the compressor control module to the ON position.

8510 High-Voltage Compressor Electrical Phase Check and Automatic ON/OFF Control

System Phase Input Checkout Procedure

To check that the correct phasing is being supplied to the On-Board cryopump, proceed as follows:

1. Press **CONTROL** key on the On-Board keypad.
2. Press **1** to turn the cryopump on.
3. If the cryopump turns on, keypad displays *CRYO ON* the system phasing is correct.
4. Press **0** to turn cryopump off.
5. If the cryopump does not turn on when 1 is pressed, keypad display reads *NO CRYO POWER 2*. This means that ***incorrect phasing is being supplied to the compressor*** from its power source.
6. To correct the phasing, interchange any two of the three phase wires at the compressor receptacle plug. See Figure 3-3.

Automatic ON/OFF Control of the Compressor Using the On-Board Setpoint Relays

The compressor remote start feature can be used with one of the On-Board setpoint relays to automatically turn the compressor on when the cryopump is turned on and turn it off when the cryopump is turned off. Disconnect the jumper on the “jumper” connector supplied and installed on the compressor REMOTE connector J5. Connect the minimum size 18AWG leads from the On-Board relay connector to the remote connector as follows:

Table 3-2: Setpoint Relay Connections

On-Board Relay Connector	8510 Remote Connector (J5)
Pin #8	D
Pin #6	E

Now program Relay 1 to the cryopump function as described below. Press the **RELAY** function key. Select Relay 1 by pressing **1**. Press the **Next** key until the display reads *CRYOPUMP*.

Press **Enter** and the display should read *FNC = CRYOPUMP* (function is cryopump operation). Press the *CONTROL* function key and the programming is complete.

NOTE: Be sure that the compressor switch is off before connecting or disconnecting the remote connector.

Multipump Installation

Your 8510 High-Voltage Compressor can be connected to more than one high-vacuum pump at a time. For example, three On-Board 8 vacuum pumps can be connected to a single 8510 High-Voltage Compressor.

CAUTION

For detailed instructions on multiple cryopump installation, refer to Appendix F.

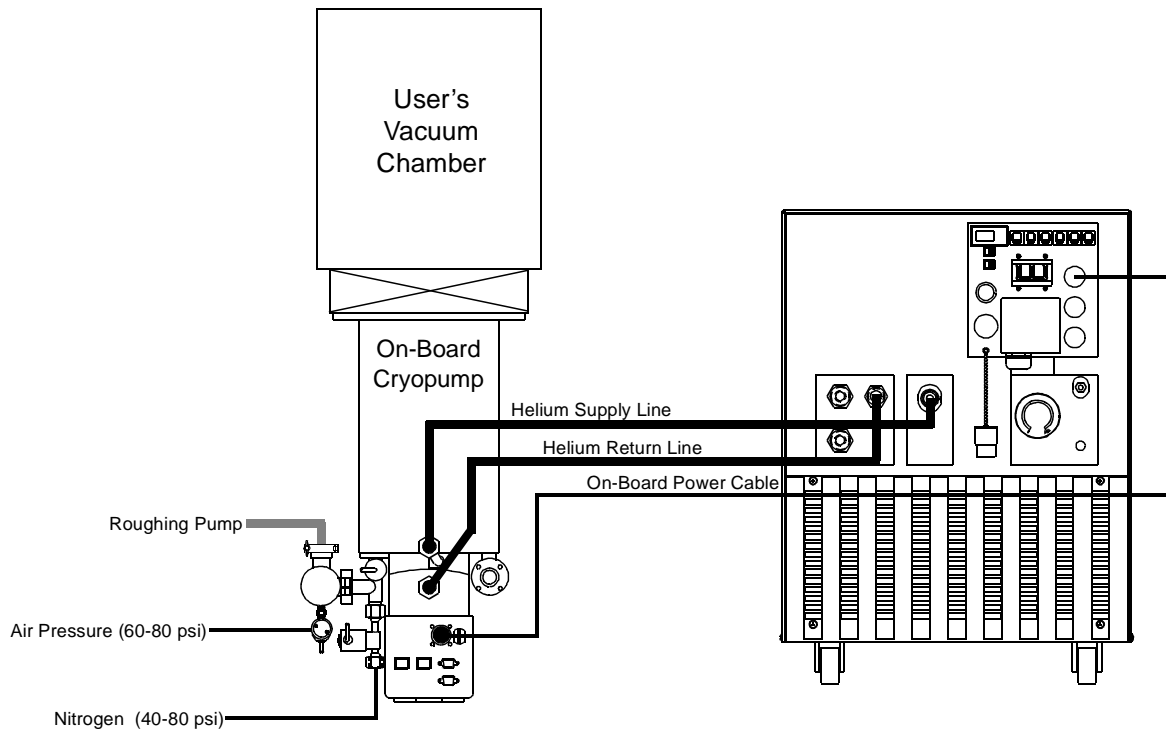

Figure 3-6: 8510 High-Voltage Compressor Installation

Section 4 - Maintenance Procedures

WARNING

Always disconnect the compressor from all sources of electrical power before performing any maintenance procedures.



Unit must be wired by an authorized electrician in accordance with the national Electrical Code, ANSI/NFPA 70-1996, as well as the local codes. This shall include installation of a readily accessible disconnect device into the fixed wiring supplying power.

An insulated safety grounding conductor that is identical in size, insulation material and thickness to the circuit supply conductors, except that it is green with or without one or more yellow stripes is to be installed as part of the branch circuit which supplies the unit or system. The grounding conductor described is to be connected to the equipment grounding conductor of the supply circuit.

Scheduled Maintenance

The only scheduled maintenance required on the 8510 High-Voltage Compressor is replacement of the compressor adsorber (P/N 8080275K001) every three years.

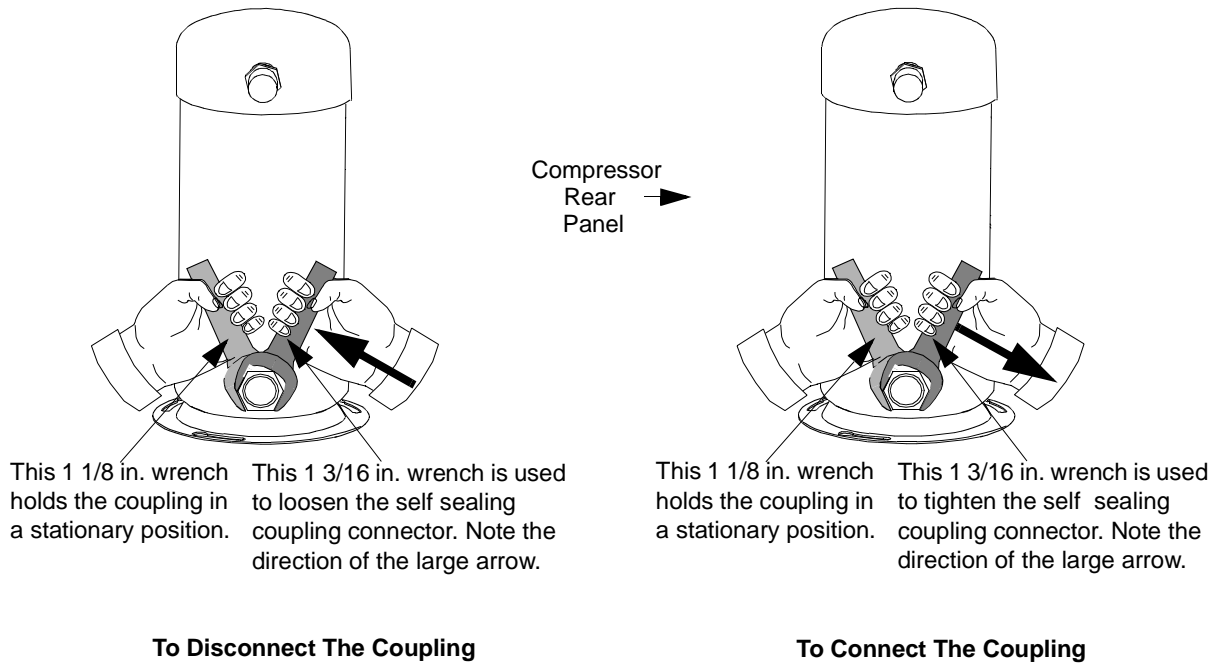

Figure 4-1: Connecting/Disconnecting the Adsorber Self-sealing Couplings

Removing the Compressor Adsorber

To remove the compressor adsorber see Figure 4-1 and proceed as follows:

1. Shut down the compressor.
2. Disconnect the compressor input power cable from its electrical power source and disconnect the water lines.
3. Disconnect the flex lines from the gas-return and gas-supply connectors at the rear of the compressor.

NOTE: Use the two wrenches supplied in the Installation and Scheduled Maintenance Tool Kit to avoid loosening the body of the coupling from its adapter. Hold one wrench fast on the coupling half attached to the rear side of the compressor. Use the other wrench to loosen the coupling on the helium supply or return line.

4. Loosen the four screws that hold the compressor rear panel and remove the panel.
5. Disconnect the adsorber-inlet self-sealing coupling. See Figure 4-1.
6. Remove the bolts, nuts, and washers that secure the adsorber to the base of the compressor. Save all hardware.
7. Carefully slide the adsorber outward until it clears the compressor and remove the adsorber.



WARNING

Depressurize the adsorber before disposing of it. Attach the depressurization fitting (included in the Installation and Scheduled Maintenance Tool Kit) to the coupling half at either end of the adsorber and tighten it slowly.

Installing the Compressor Adsorber

1. Install the replacement adsorber as follows:
 - a. Remove the dust caps from the self-sealing coupling halves at each end of the replacement adsorber.
 - b. Install the replacement adsorber following the steps for compressor adsorber removal in reverse order. Use the hardware saved in step 6 above.
2. Connect the adsorber to the compressor internal piping as follows:
 - a. Check the self-sealing connector flat rubber gasket to make sure that it is clean and properly positioned.
 - b. Make the first turns by hand and then firmly seal the connection using the two wrenches until the fittings “bottom”.

CAUTION

Make sure to hold fast on the left coupling nut while tightening the right coupling nut, as shown in Figure 4-2.

- c. Using the two wrenches supplied in the Installation and Scheduled Maintenance Tool Kit, make the connection quickly to minimize minor gas leakage. See Figure 4-1.
3. Replace the panel and secure it by tightening the four screws.
4. Ensure that the pressure gauge reads 195-205 psig (1345-1415 kPa). If additional gas pressure is required, follow the instructions under, **Adding Helium Gas**. Record the date that the adsorber was replaced, and also make a note that the next adsorber replacement is in three years.
5. Connect the flex lines to the gas-return and gas-supply connectors at the rear of the compressor.

6. Connect the water lines to the compressor fittings and secure with hose clamps. If hard piping is used, apply a light coating of plumbing thread sealant on threads and install water lines onto the compressor. DO NOT OVERTIGHTEN.

CAUTION

Check water connections for leaks.

7. Connect the cold head power cables to the compressor connectors.
8. Plug the compressor input power cable into the power source.

Unscheduled Maintenance

Suggested Unscheduled Maintenance Equipment

It is advisable to keep on hand the unscheduled maintenance equipment and disposable supplies listed below.

1. Helium, 99.999% pure.
2. Pressure regulator (0-3000/0-400 psig).
3. Maintenance manifold, P/N 8080250K003*.
4. Helium charging line terminating in a 1/4-inch female flare fitting, P/N 7021002P001.
5. Installation and Scheduled Maintenance Tool Kit, P/N 8032040G014.

*Available from stock; consult the factory or your sales representative.

Adding Helium Gas

Use only 99.999% pure helium gas.

CAUTION

If the compressor helium pressure gauge reads 0, decontamination is required. Refer to **Compressor Decontamination Procedures**, or contact the Product Service Department.

1. A User-supplied helium charging line terminating in a 1/4-inch female flare fitting, and a two-stage pressure regulator rated at 0-3000/0-400 psig is required for this operation.

2. If you need to add helium more than once every several months, check for leaks caused by improperly connected self-sealing connections or any mechanical joint within the compressor.

There are two conditions that require the addition of helium gas:

1. Compressor not operating; helium pressure gauge reads 195 psig (1345 kPa), or below.
2. Compressor operating; helium pressure reads 75 psig (517 kPa), or below.

To add helium gas:

1. Attach a two-stage regulator (0-3000/0-400 psig) and charging line to a helium gas (99.999% pure). **DO NOT OPEN THE BOTTLE AT THIS TIME.** Purge the regulator and charging lines as instructed in steps a through e below. Do *not* use helium gas that is *less than 99.999% pure*.
 - a. Open the regulator a small amount by turning the adjusting knob clockwise until it contacts the diaphragm, then turn approximately 1/8 to 1/4 turn more, so that the regulator is barely open.
 - b. Slowly open the bottle valve, and purge the regulator for 10 to 15 seconds. Turn the regulator knob counterclockwise until the helium stops flowing.
 - c. Connect the charge line to the helium pressure regulator.
 - d. Remove the flare cap of the gas charge fitting on the rear of the compressor. Loosely connect the charge line to the charge fitting.
 - e. Set the helium pressure regulator to 10 to 25 psig (70-125 kPa). Allow helium gas to flow through the charging line and around the loosened flare fitting for 30 seconds to purge the charging line of air. Then tighten the flare nut at the end of the charge line.

(This procedure is required to ensure that both the regulator and the charging line will be purged of air and that the air trapped in the regulator will not diffuse back into the helium bottle. For best results, CTI-CRYOGENICS suggests a dedicated helium bottle, regulator, and line, which are never separated, for adding helium.)

2. Set the helium pressure regulator to 300 psig (2070 kPa). Depending on the compressor operating state, add helium gas:

- a. If the compressor is running (approximately 2 hours operating time) under normal operating conditions, slowly open the helium charge valve on the rear of the compressor. When the helium pressure gauge rises to 75-85 psig (517-590 kPa) tightly close the charge valve.
- b. If the compressor is not running, slowly open the helium charge valve. When the helium pressure gauge rises to 195-205 psig (1345-1415 kPa), tightly close the charge valve.

CAUTION

Add helium gas slowly to prevent relief valve blow-off.

3. Ensure that the helium charge valve on the compressor is tightly closed. Shut off the helium pressure regulator on the helium bottle and remove the charging line from the male flare fitting. Shut off the helium gas bottle valve. Reinstall the flare cap.

Helium Circuit Decontamination

Contamination of the helium-gas circuit is indicated by sluggish or intermittent operation (ratchetting) of the cold head drive mechanism. With severe contamination the cold head drive may seize and fail to operate. One of the major sources of contamination is using helium gas of less than the required purity. When performing the decontamination process, use only 99.999% pure-helium gas, and the regulator and charging line must be properly connected and purged. This contamination procedure will remove contaminants from the cold head and/or compressor, thereby restoring system performance. The cold-trapping of contaminants inside the cold head during this procedure will also decontaminate the compressor if the contamination of the system is not severe. Separate decontamination of the compressor is required whenever the compressor has been opened to atmosphere, or the pressure dropped to zero.

Cryopump Decontamination Procedures

1. Cool down the cryopump and operate it for one to three hours. If the system will not cool down, proceed to step 2. Operating the cryopump will isolate the contaminants by “freezing” them in the cold head. The contaminants in the helium-gas circuit of the cryopump tend to become frozen inside the cold head. The longer the cryopump is operated beyond the one-hour period, the greater is the amount of contamination that becomes isolated inside the cold head.

2. Shut down the compressor as follows:
 - a. Close the Hi-Vac valve in your vacuum system.
 - b. Turn off the system power ON/OFF switch.

CAUTION

Exposing the cryopump to atmosphere during warm-up will cause excessive water vapor adsorption by the charcoal of the 15K array.

3. **Immediately** disconnect the helium-gas supply and helium-gas return lines from the gas-supply and gas-return connectors at the rear of the compressor. Leave them attached to the cold head.
4. Attach the maintenance manifold (P/N 8080250K003) to the disconnected ends of the helium-gas return and helium-gas supply lines.
5. Reduce the pressure in the cold head to a level of 45 psig by using the maintenance manifold.
6. If you have the automatic REGEN ON-BOARD option, start a regeneration and then discontinue it when the cryopump reaches 300K. If you only have the manual regeneration option, turn the cryopump off and open the purge valve until the second stage reaches room temperature.
7. Allow the second stage of the cold head to warm up to room temperature. Warm-up time can be reduced by purging the cryopump with warm dry argon or nitrogen gas. Using the gas heater, CTI P/N 8080250K020, will reduce warm-up time about 50 percent, and will maintain the gas temperature below the 150°F (66°C) limit.
8. Once the cryopump has reached room temperature, attach a two-stage regulator (0-3000/0-400 psig) and charging line to a helium bottle (99.999% pure). **DO NOT OPEN THE BOTTLE VALVE AT THIS TIME.** Purge the regulator and charging line as instructed in steps a through e in, **Adding Helium Gas**. Do *not* use helium gas that is *less than 99.999% pure*.
9. Perform in sequence:
 - a. Backfill the cold head and helium-gas return and supply lines with helium to a static charge pressure of 195-205 psig (1345-1415 kPa) by adjusting the regulator to the required pressure, and opening the valve on the manifold. Close the valve when the pressure is correct.

- b. Depressurize the cold head by *slowly* opening the ball valve and allowing the helium to bleed out slowly. Do *not* reduce the pressure to *less than* 30 psig or the cold head may be further contaminated.
 - c. Perform flushing steps a and b three more times.
 - d. Pressurize the cold head to the static charge pressure of 195-205 psig (1345-1415 kPa) and run the cold head drive motor for 10 to 30 seconds by actuating the controller ON/OFF switch to on.
 - e. Perform steps b through d three more times for a total of 16 flushes and a total of 4 drive-motor runs.
10. Verify that the cold head is pressurized to the static charge pressure of 195-205 psig (1345-1415 kPa).
 11. Disconnect the maintenance manifold from the helium-gas return and helium-gas supply lines.
 12. Reconnect the helium-gas return and helium-gas supply lines to the return and supply connectors at the rear of the compressor. The cryopump is now ready for operation.

Compressor Decontamination Procedures

The procedure to decontaminate a compressor is similar to the above procedure with certain exceptions.

- There is no need to operate the cryopump before decontaminating the compressor.
 - The maintenance manifold and helium-gas supply and helium-gas return lines will be connected to the supply and return fittings on the compressor.
1. Open the ball valve slightly on the maintenance manifold and allow the helium to bleed out and depressurize the compressor (if pressurized) to 30 psig.
 2. Charge the compressor slowly to approximately 200 psig (1380 kPa) by opening the 1/8-inch valve on the maintenance manifold.
 3. Run the compressor for about 30 seconds.
 4. Repeat steps 1 and 2, one time.
 5. Disconnect the maintenance manifold from the helium-gas return and helium-gas supply lines.

6. Reconnect the helium-gas return and helium-gas supply lines to the return and supply connectors on the cold head. The compressor is now ready for operation.

NOTE: *After connecting the compressor to the cryopump, and operating the system for a period of time, it may be necessary to decontaminate the cryopump as some residual contamination from the compressor may become trapped in the cold head. If the entire system was reduced to zero psig (a broken flex line, for example), then the cryopump and compressor would have to be decontaminated according to the section, **Cryopump Decontamination Procedures**.*

Priming the Compressor Oil System

The oil-prime manifold (P/N 8018129) supplied with the 8510 Low-Voltage Compressor is used to prime the compressor oil system when any of the following conditions exist:

1. The compressor has been inoperative for a period of three months or longer.
2. The compressor is not operating and the supply pressure gauge reads 0 psig. If this condition exists contact the Product Service Department for corrective action before priming the compressor.
3. The compressor has automatically shut off because of a loss of helium supply pressure.

Priming procedures are:

1. Disconnect the helium return and supply lines from the rear of the compressor.
2. Install the oil-prime manifold on the compressor supply and return connectors.
3. Ensure that the pressure gauge reads 195-205 psig (1345-1415 kPa). If additional gas pressure is required, follow the instructions under, **Adding Helium Gas**.
4. Turn the compressor switch to the ON position and allow the compressor to run between 15 and 30 minutes.
5. After completing the oil-system priming turn off the compressor and remove the oil-prime manifold.
6. Reconnect the helium return and supply lines on the rear of the compressor.

Appendix A - Customer Support Centers

Introduction

Refer to Table A-1 for the nearest Customer Support Center for technical assistance or service. North American customers may call 800-FOR-GUTS (800-367-4887) 24 hours a day, seven days a week. All other customers must call their local Customer Support Center.

Please have the following information available when calling so that we may assist you:

- Product Part Number
- Product Serial Number
- Product Application
- Specific Problem Area
- Hours of Operation
- Equipment Type
- Vacuum System Brand/Model/Date of Manufacture

For your convenience, you may also e-mail us at:

techsupport@helixtechnology.com

Visit us at our corporate website:

www.helixtechnology.com

Table A-1: Customer Support Centers

<p>United States and Canada</p> <p>Helix Technology Corporation Customer Response Center Nine Hampshire Street Mansfield, Massachusetts 02048 U.S.A. Tel: 508-337-5000 Tel: 800-379-7224 (within USA) Fax: 508-337-5169</p> <p>Dial: 800-FOR-GUTS (800-367-4887) 24 hours a day, seven days a week</p>	<p>United States and Canada</p> <p>Helix Technology Corporation 3350 Montgomery Drive Santa Clara, California 95054 U.S.A. Tel: 408-592-5940 Tel: 800-324-6449 (within USA) Fax: 408-988-6630</p> <p>Dial: 800-FOR-GUTS (800-367-4887) 24 hours a day, seven days a week</p>
<p>United States and Canada</p> <p>Helix Technology Corporation 4120 Freidrich Lane Suite 600 Austin, Texas 78744 U.S.A. Tel: 512-912-2800 Tel: 800-324-6445 (within USA) Fax: 512-912-2888</p> <p>Dial: 800-FOR-GUTS (800-367-4887) 24 hours a day, seven days a week</p>	<p>United States and Canada</p> <p>Helix Technology Corporation Colorado Operations 6450 Dry Creek Parkway Longmont, Colorado 80503 U.S.A. Tel: 303-443-7660 Tel: 800-776-6543 (within USA) Fax: 303-443-2546</p> <p>Dial: 800-FOR-GUTS (800-367-4887) 24 hours a day, seven days a week</p>

Table A-1: Customer Support Centers (Continued)

<p>Germany, Italy, Denmark, Switzerland, Holland, Norway, The Netherlands</p> <p>Helix Technology Corporation Haasstrasse 15 D-64293 Darmstadt Germany Tel: +(49) 6151-959-55 Fax: +(49) 6151-959-57</p> <p>Dial: +(49) 6151-959-55 24 hours a day, seven days a week</p>	<p>France, Spain, Portugal, Greece</p> <p>Helix Technology Domaine Technologique de Saclay 4, rue Rene Razel, Bât Apollo F-91892 Orsay Cedex France Tel: +(33) 1-6935-2600 Fax: +(33) 1-6985-3725</p> <p>Dial: +(33) 1-6935-2600 24 hours a day, seven days a week</p>
<p>United Kingdom, Ireland, Sweden, N. Ireland</p> <p>Helix Technology Corporation Fleming Road Kirkton Campus Livingston, West Lothian Scotland EH54 7BN Tel: +(44) 1-506-460017 Fax: +(44) 1-506-411122</p> <p>Dial: +(44) 1-506-460017 24 hours a day, seven days a week</p>	<p>Japan</p> <p>Helix Technology Corporation Queens Tower A 14F 3-1, Minatomirai 2-chome Nishi-ku, Yokohama Japan 220-6014 Tel: +(81) 45-682-5470 Fax: +(81) 45-682-5475</p> <p>Dial: +(81) 45-682-5470 24 hours a day, seven days a week</p>
<p>Korea</p> <p>Helix Technology Zeus Company, Ltd. Zeus Building 3-16, Yangjae-Dong, Socho-ku Seoul 137-130, Korea Tel: +(82) 2-577-3181/3186 Fax: +(82) 2-576-3199</p> <p>Dial: +(82) 2-577-3181 24 hours a day, seven days a week</p>	<p>Taiwan</p> <p>Helix Vacuum Technology Limited 4F-1 No. 81 Shui Lee Road Hsin-Chu 300, Taiwan</p> <p>Tel: +(886) (3) 572-3999 Fax: +(886) (3) 571-7670</p> <p>Dial: +(886) (3) 516-9022 24 hours a day, seven days a week</p>

Table A-1: Customer Support Centers (Continued)

<p>China</p> <p>Helix Technology Corporation Tritex International Company Da An Square, 9A Middle Bldg 829 Yan An Middle Road Shanghai, 200040 China Tel: +(86) 21-6279-1389 Fax: +(86) 21-6247-1539</p> <p>Dial +(86) 21-6279-1389 24 hours a day, seven days a week</p>	<p>Australia, New Zealand, Tasmania</p> <p>Helix Technology Corporation CTI-Cryogenics Products AVT Services Pte. Ltd. Unit 1, 12 Pioneer Avenue Thornleigh NSW 2120 Sydney, Australia Tel: +(612) 9-4810748 Fax: +(612) 9-4810910</p> <p>Dial: +(612) 9-4810748 24 hours a day, seven days a week</p>
<p>Australia, New Zealand, Tasmania</p> <p>Helix Technology Corporation Granville-Phillips Products Stanton Scientific 2/6 Jonson St. Byron Bay, NSW 2481 Australia Tel: +(61) 66-856-902 Fax: +(61) 66-858-530</p>	<p>Singapore, Malaysia, Philippines, Indonesia</p> <p>Helix Technology Corporation APP Systems Services Pte Ltd. 2 Corporation Road #06-14 Corporation Place Singapore 2261 Tel: +(65) 268-2024 Fax: +(65) 268-6621</p> <p>Dial: +(65) 268-2024 24 hours a day, seven days a week</p>

Table A-1: Customer Support Centers (Continued)

<p>India</p> <p>Helix Technology Corporation CTI-Cryogenics Products Goodwill Cryogenics Enterprise 213 Nirman, Sec. 17, Vashi New Bombay, 400703 India Tel: +(91) 22-7632906 Fax: +(91) 22-7822769</p> <p>Dial: +(91) 22-7632906 24 hours a day, seven days a week</p>	<p>India</p> <p>Helix Technology Corporation Granville-Phillips Products Ashwini Enterprises C-2/13/03, Sector-16, Vashi New Bombay 400 705 India Tel: +(91) 22-766 1107 Fax: +(91) 22-766 2631</p>
<p>Israel</p> <p>Helix Technology Corporation CTI-Cryogenics Products Vacuum System & Technology Ltd. P.O. Box 4137 Petach Tikva 49130 Israel Tel: +(972) 3-9247710 Fax: +(972) 3-9247711</p> <p>Dial: +(972) 3-9247710 24 hours a day, seven days a week</p>	<p>Israel</p> <p>Helix Technology Corporation Granville-Phillips Products El-Tan Technologies P.O. Box 1020 Hod-Hasharon 45110 Israel Tel: +(972) 9-740-5551 Fax: +(972) 9-740-6690</p>

Appendix B - Troubleshooting Procedures

Troubleshooting the Compressor

The compressor troubleshooting procedures are summarized in Table B-1.

Technical Inquiries

Please refer to Appendix A of this manual for a complete list of the CTI-CRYOGENICS' world wide customer support centers.

WARNING



Disconnect the compressor before performing any troubleshooting procedures.

The compressor pump is hot after operating. Wait for the pump to cool down before working on the inside of the compressor

Do not change or modify any compressor internal wiring circuits, this may cause failure of the compressor and cold head due to improper phasing.

Table B-1: Compressor Troubleshooting Procedures

Problem	Possible Cause	Corrective Action
<p>1) System power ON/OFF switch (CB1) and compressor switch (S1) remains in the ON position when switched on but the compressor will not run. Refer to Figure C-1 for identification of all electrical components</p>	<p>1) Incorrect phasing of input power causing phase monitor switch to remain open</p> <p>2) No power coming from the source.</p> <p>3) Insufficient voltage at power source causing phase monitor switch to remain open.</p> <p>4) Control circuit fuses missing or blown.</p> <p>5) Improperly wired external remote control circuit. This will apply only if the remote control feature <i>is being</i> utilized.</p> <p>6) Incorrect control circuit voltage.</p> <p>7) Excessive current drawn by the compressor pump has caused the overload relay in the motor contactor (MI) to open.</p>	<p>1) Check phasing of input power from the source against its schematic, Figure 3-5.</p> <p>2) Check source fuses, circuit breakers, and wiring associated with the power source, and repair as needed.</p> <p>3) Verify adequate phase to phase input voltage. Refer to Table 1-2</p> <p>4) Check control fuses F1, F2, and F3. If any of these fuses are blown, contact the Product Service Department.</p> <p>5) Verify correct installation of remote control feature per Table 3-2.</p> <p>6) Check the voltage setting on switches S2 and S3 per Figure 3-6.</p> <p>7) a. Reset the overload relay in the motor contactor. Refer to Figure C-1, for its location. b. Contact the Product Service Department.</p>

Table B-1: Compressor Troubleshooting Procedures

Problem	Possible Cause	Corrective Action
2) System power ON/OFF switch (CB1) will not remain in the ON position when switched on. The switch circuit breaker trips when excessive current is being drawn by the cold head or 24-volt compressor control circuits.	1) Damaged On-Board power cable, connectors or drive motor. 2) Damaged component in the compressor power or control circuit.	1) Check for compressor operation with each cold head connection (J10, J11, J12) disconnected from compressor. Contact the Product Service Department if the compressor operates improperly. 2) Contact the Product Service Department.
3) System power ON/OFF switch (CB1) remains in the ON position, and the compressor stops after several minutes of operation and remains off.	1) Loss or degradation of power coming from power source. 2) Thermal protective switches are open. 3) Very cold cooling water has caused a restriction of oil flow through the oil injection orifice during start-up.	1) Ensure a constant supply of power per Table 1-2. 2) Check for inadequate water cooling, see Table 1-3. 3) Recheck for proper cooling water temperature per Table 1-3. Restart the compressor repeatedly until continuous operation is achieved.

Appendix C - Electrical Schematic for 8510 High-Voltage Compressor

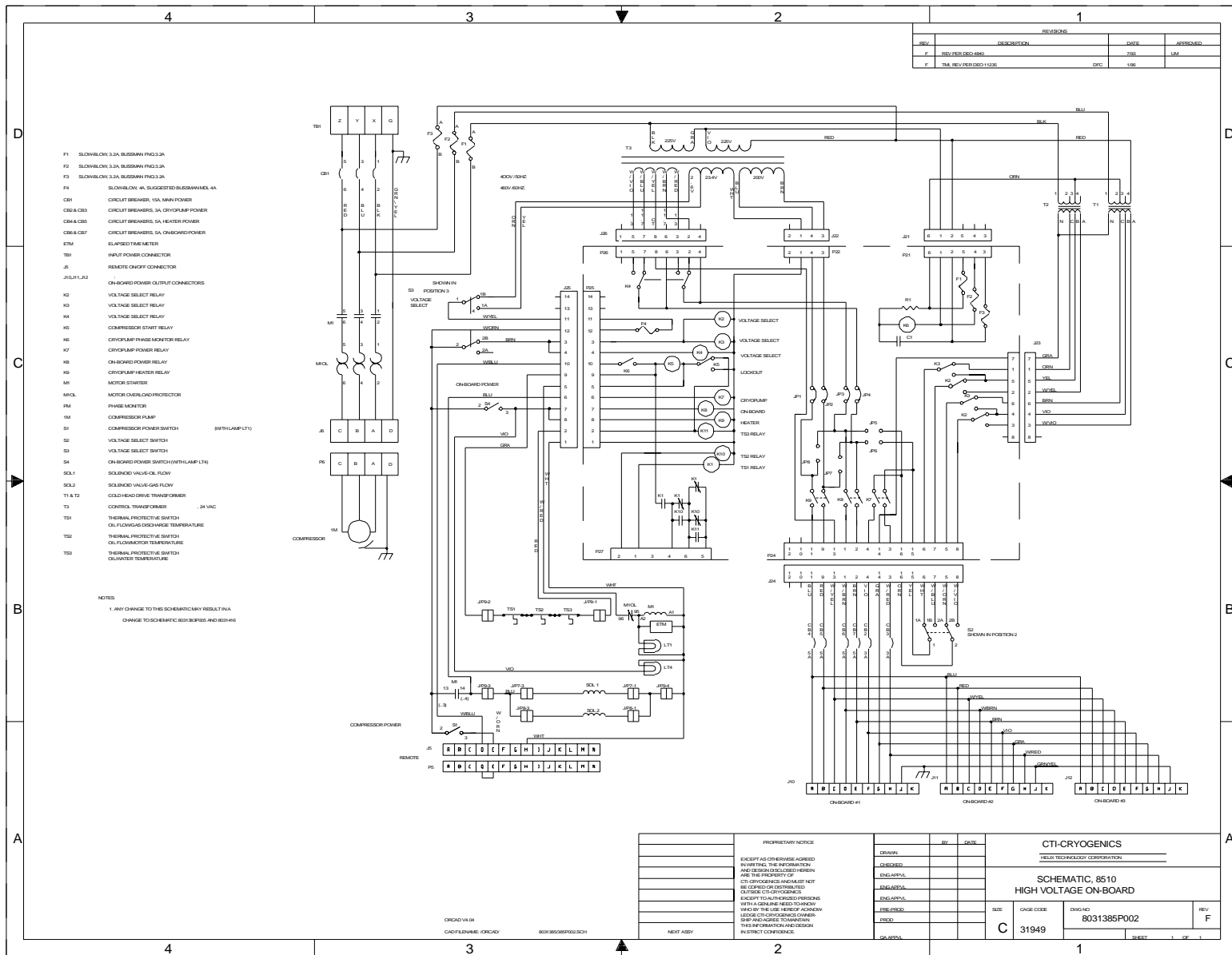

Figure C-1: 8510 (High Voltage) Compressor Schematic

Appendix D - Components in the Electrical Control Module of 8510 High-Voltage Compressor

Table D-1: Legend for Figure D-1

Item Number	Description	Symbol Designation
1	Printed Wire Array Assembly	PWA1
2	Control Transformer, 24 VAC	T3
3	Cold Head Drive Transformer	T2
4	On-Board Power Switch (with Lamp LT4)	S4
5	Compressor Power Switch (with Lamp LT1)	S1
6	Cold Head Drive Transformer	T1
7	Fuse - 4A, Slow-Blow, MDL 4A	F4
8	Fuse - 3.2A, Slow-Blow, FNQ 3.2A	F3
9	Fuse - 3.2A, Slow-Blow, FNQ 3.2A	F2
10	Fuse - 3.2A, Slow-Blow, FNQ 3.2A	F1
11	Motor Starter	M1
12	Phase Monitor	PM
13	Motor Overload Protector	M10L
14	Voltage Select Switches	S2, S3
15	Motor Starter Reset	M1 RESET
16	Remote ON/OFF Connector	J5
17	Circuit Breaker, 25A, Main Power	CB1
18	Input Power Connector	TB1
19	On-Board Power Output Connector	J12
20	On-Board Power Output Connector	J11
21	On-Board Power Output Connector	J10
22	Circuit Breaker, 3A, Cryopump Power	CB3
23	Circuit Breaker, 3A, Cryopump Power	CB2

Table D-1: Legend for Figure D-1

Item Number	Description	Symbol Designation
24	Circuit Breaker, 5A, On-Board Power	CB7
25	Circuit Breaker, 5A, On-Board Power	CB6
26	Circuit Breaker, 5A, Heater Power	CB5
27	Circuit Breaker, 5A, Heater Power	CB4
28	Elapsed Time Meter	ETM

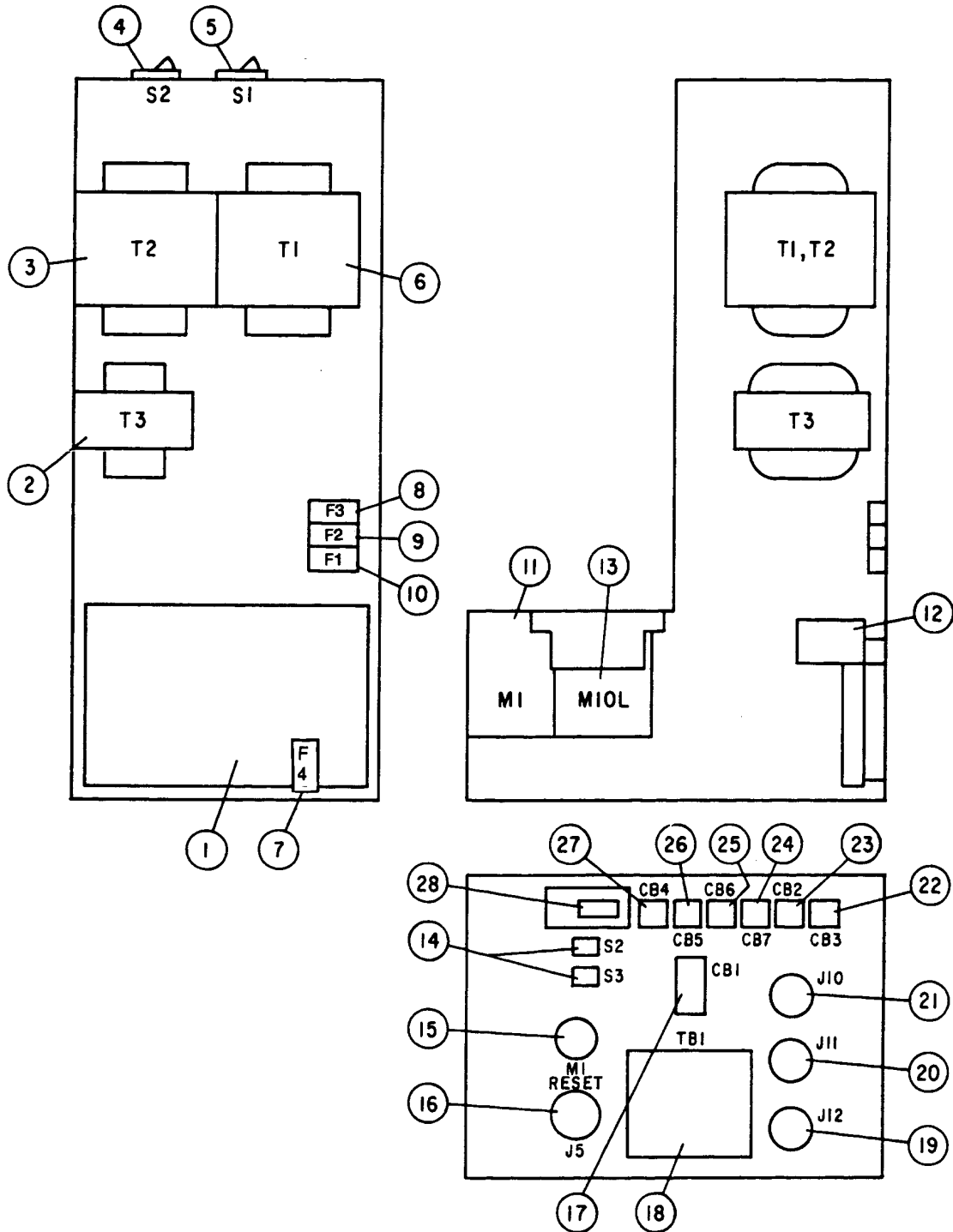

Figure D-1: Components in the Electrical Control Module of 8510 High-Voltage Compressor

Appendix E - Compressor Flow Diagram

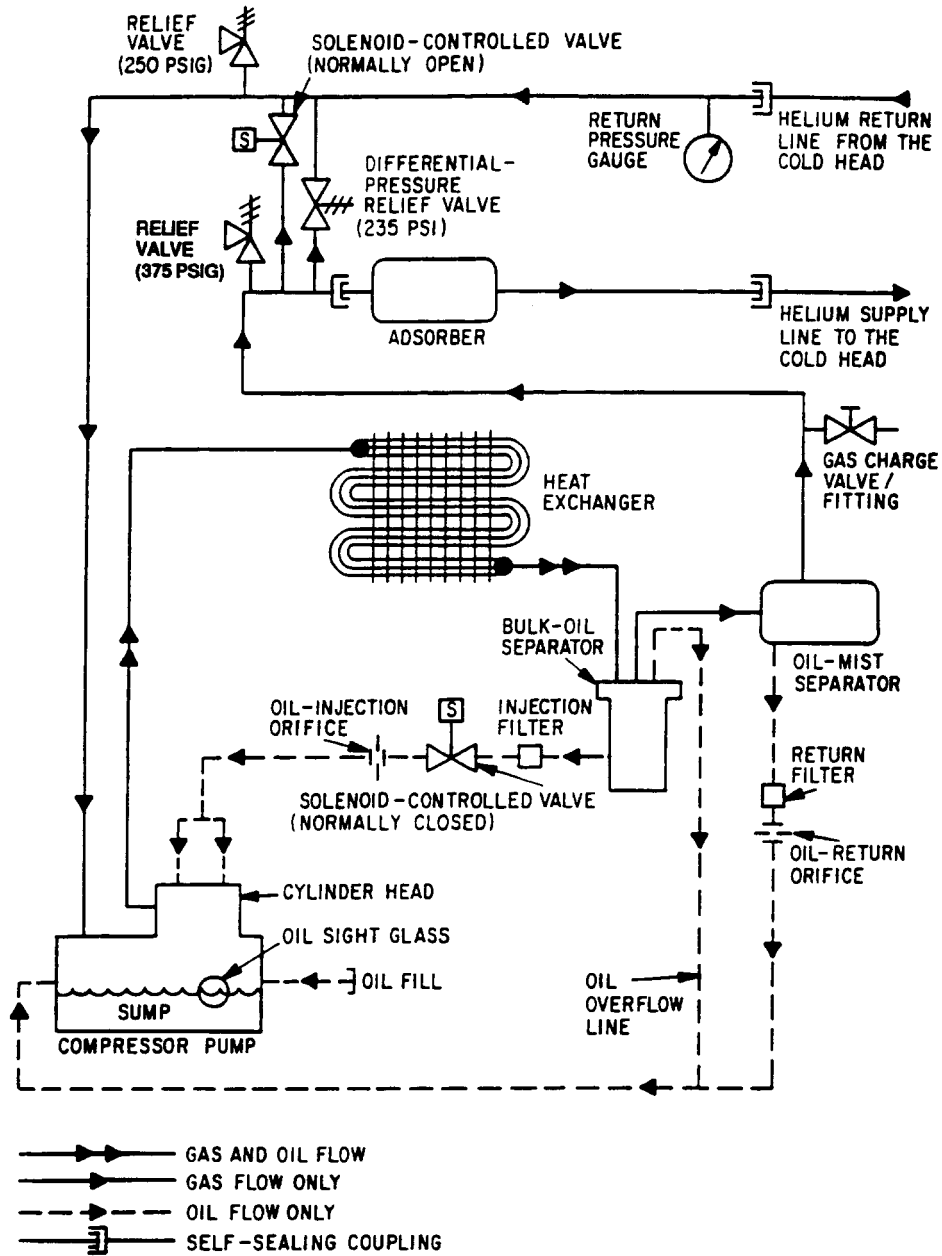

Figure E-1: 8510 High-Voltage Compressor Flow Diagram

Appendix F - Multiple Cryopump Installation with Single 8510 High-Voltage Compressor

Your 8510 Compressor may be used to drive a number of multiple On-Board cryopump combinations.

Figure F-1 depicts a typical multi-cryopump installation with an 8510 High-Voltage Compressor. As shown in this figure, a power cable is connected from the compressor to each cold head; also, the components are helium connected in parallel (all supply fittings piped together).

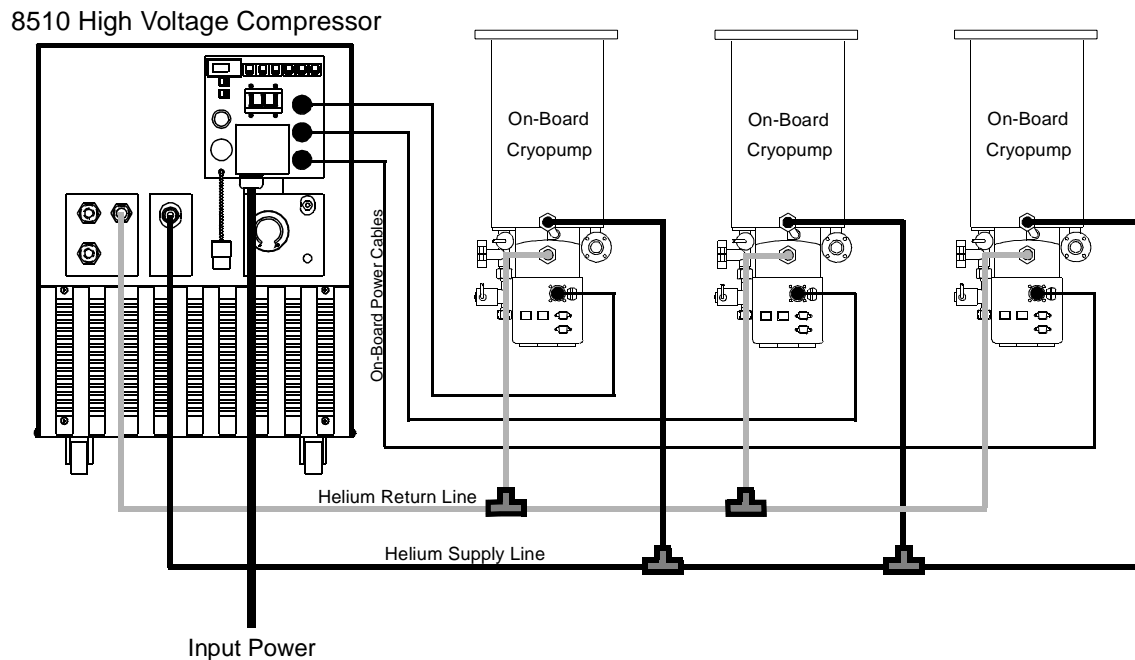

Figure F-1: Typical Multiple Cryopump Installation with Single 8510 High-Voltage Compressor

Shown in Figure F-1 is a typical multiple cryopump installation. If you are considering a multiple cryopump installation please contact the CTI-CRYOGENICS, U.S.A., Application Engineering Department (1-800-447-5007) for technical assistance in the selection and sizing of the manifolds and interconnecting lines for your particular installation.

Preliminary System Requirements

Installation of the 8510 Low-Voltage Compressor for use with a single cryopump is covered in **Section 3 - Installation**. Installation for multiple cryopump usage is similar, but requires that system charge pressure be established for a given high-vacuum pump system. Additionally, the following parameters must be considered before the system can be assembled.

- All system components must be assembled and be operational for system static charge pressure determination.
- All system components must have static charge pressures of 195-205 psig at 70° F to 80° F (21° C to 27° C).

Determining System Charge Pressure

To establish the helium gas charge pressure of a multiple cryopump installation proceed as follows:

1. Assemble your multiple cryopump system components.
2. Check the compressor pressure gauge to insure static pressure is in the 195-205 psig (1345-1415 kPa) range.
3. If it is necessary to reduce helium gas pressure then perform the following:
 - a. Disconnect the charging line from gas charge fitting on rear of compressor.
 - b. Open the gas charge valve very slowly. Allow helium gas to escape until pressure gauge reads 50-100 psig (345-690 kPa).
 - c. Close the gas charge valve and reinstall the charging line to the gas charge fitting, refer to step 4 for procedure.
4. If the pressure is low, attach a helium bottle, regulator, and charging line to the compressor and perform the following:
 - a. Remove the flare cap of the gas charge fitting on the rear of the compressor.
 - b. Loosely attach a charging line from the helium pressure regulator on the helium bottle to the 1/4-inch male flare fitting installed on the helium charge fitting of the compressor.

NOTE: Use only 99.999% pure helium.

- c. Set the helium pressure regulator to 10 to 25 psig (70-125 kPa). Allow helium gas to flow through the charging line

and around the loosened flare fitting for 30 seconds to purge the charging line of air. Then tighten the flare nut at the end of the charge line.

- d. Slowly add helium gas until compressor pressure gauge reads 195-205 psig (1345-1415 kPa).
5. Turn on the system power ON/OFF switch.
6. Note helium pressure gauge reading immediately after startup. It should read 50-100 psig (345-690 kPa). If necessary add additional helium gas by slowly opening the helium charge valve on the rear of the compressor until the helium pressure gauge rises to 50-100 psig (345-690 kPa).
7. Allow the cryopump to operate until a cooldown temperature of 20K or less is reached.

Adjust the helium pressure if necessary as described in step 6 until the helium pressure gauge reads 80-100 psig (550-690 kPa) while the system is operating.

8. Allow the system to reach steady state. Recheck the helium pressure.
9. When steady state is achieved, shut the system off and allow the system time to reach steady state conditions at room temperature.
10. When the system reaches room temperature, the pressure reading on the compressor gauge is the system charge pressure.

NOTE: Record the compressor static pressure in your operating log. This is the static pressure for your particular installation and should be used for checking compressor performance or when troubleshooting the installation.

11. Ensure that the helium charge valve on the compressor is tightly closed. Then shut off the helium pressure regulator or the helium bottle. Remove the charging line from the male flare fitting and reinstall the flare cap.